

FS Micro Pumping Station

The *FS Micro* is a pre-assembled ready for use automatic pump station.

Suitable for extensions, garden rooms and small sewage applications.

The standard pumping station consists of the SEMISOM 450L submersible pump.

Pump Features

- Stainless steel motor casing
- Coolant filled motor
- Mechanical seal
- 10 metre cable
- Float switch as standard

Tank features

- Polyethylene tank
- 300L capacity
- screw down lid
- 1x 110mm/160mm inlets

- Special audible/visual alarm control box available - ask for details

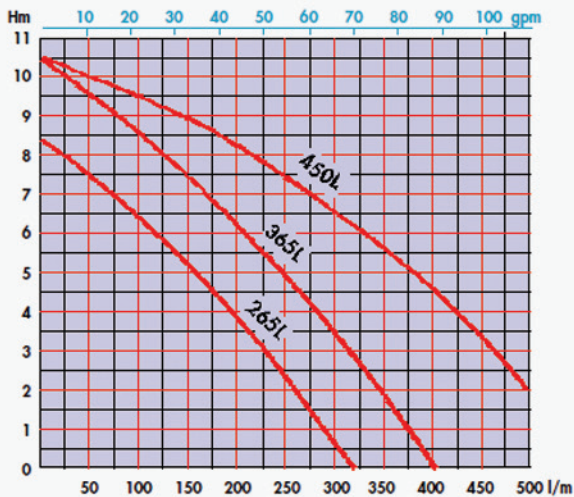
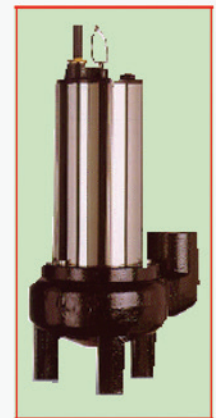
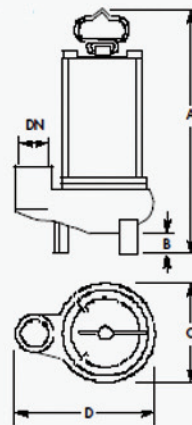
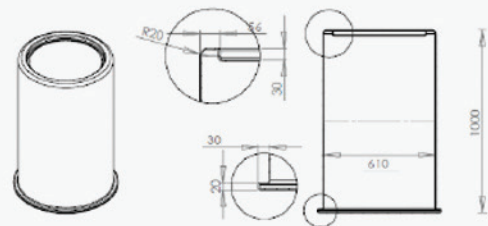
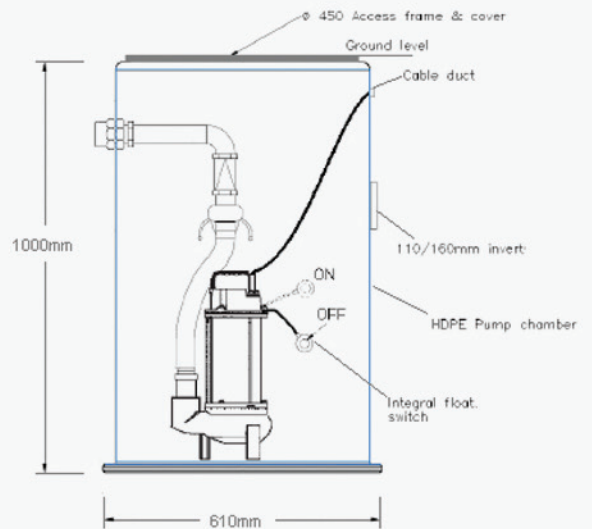

TECHNICAL DATA											
MODEL	NOMINAL		NOMINAL AMP			DIMENSIONS mm					WEIGHT Kg
	kW	HP	110V	230V	400V	A	B	C	D	DN	
265L	0.55	0.75	8.5	4.2	1.7	400	50	162	230	1½"	13.5
365L	0.75	1.0	13.0	5.5	2.3	440	50	162	230	1½"	16.5
450L	1.1	1.5	14.5	7.3	2.7	464	50	183	260	2"	19.2