

## Sewbox Pumping Station

The *SewBox* is a pre-assembled ready for use automatic pump station, particularly suitable when the water from drains is collected at lower than the main sewer.

The standard pumping station consists of the SEMISOM 450L submersible pump.



### Pump Features

- Cast iron/Stainless steel construction
- Coolant filled motor
- Mechanical seal
- 10 metre cable
- Float switch as standard

### Tank features

- Polyethylene tank
- 170L capacity
- screw down lid
- 2x 110mm inlets
- *Special audible/visual alarm control box available - ask for details*

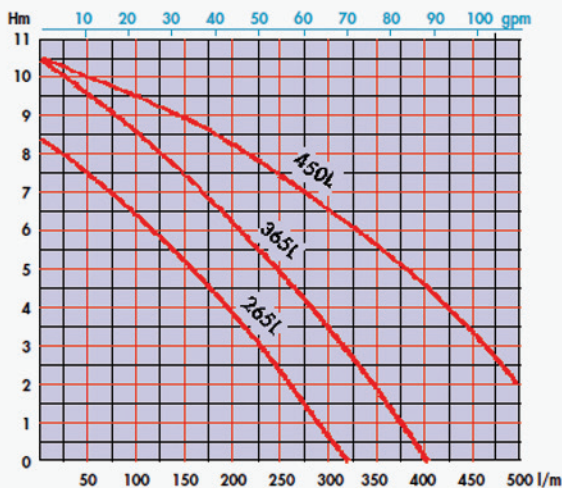
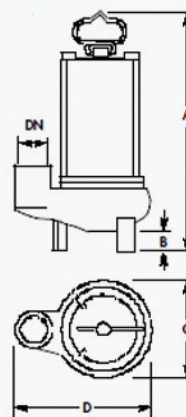
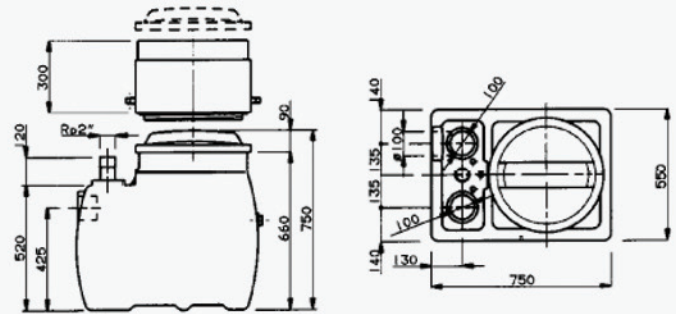

TECHNICAL DATA											
MODEL	NOMINAL		NOMINAL AMP			DIMENSIONS mm				WEIGHT Kg	
	kW	HP	110V	230V	400V	A	B	C	D		DN
265L	0.55	0.75	8.5	4.2	1.7	400	50	162	230	1½"	13.5
365L	0.75	1.0	13.0	5.5	2.3	440	50	162	230	1½"	16.5
450L	1.1	1.5	14.5	7.3	2.7	464	50	183	260	2"	19.2